

**Digital Undercounter  
 Refrigerated Counter Saladette - 250lt, 2  
 Doors with lid and chopping board  
 (R290)**

ITEM # \_\_\_\_\_

MODEL # \_\_\_\_\_

NAME # \_\_\_\_\_

SIS # \_\_\_\_\_

AIA # \_\_\_\_\_

**725107 (SAL25L2C9)**

 2-door refrigerated  
 Saladette with lid and  
 chopping board 250lt, +2+10°  
 C, AISI 304

### Short Form Specification

**Item No.** \_\_\_\_\_

Constructed entirely in 304 AISI stainless steel. High-density expanded polyurethane foam, 45 mm in thickness, with cyclopentane injection. Height-adjustable feet. Hinged lid on top. Lower refrigerated compartment designed to accommodate GN 1/1 containers and equipped with N. 2 hinged doors. Built-in refrigeration unit. Ventilated. Refrigerant R290. Digital control panel. Automatic evaporation of defrost water. Suitable to operate in ambient temperatures up to +43°C. Temperature range: 0+10°C. CFC and HCFC free. Supplied with n.9 horizontal container supports and n.1 non-toxic plastic chopping board.

### Main Features

- Forced air circulation for rapid cooling and an even temperature distribution.
- Automatic evaporation of defrost water. Prearrangement for drain outlet.
- Connectivity ready for real time access to connected appliances from remote and data monitoring (requires optional accessory).
- Digital control panel.
- Equipped with hinged lid for non-operating periods.
- Anti-tilt runners accept GN 1/1 containers.
- A kit of wheels is available as optional accessory for easier movement.
- Adjustable temperature range from 0°C to +10°C.
- Tropicalized unit.

### Construction

- IPX3 protected.
- Adjustable feet 66-88 mm (see optional accessory).
- Built-in compressor to suit operating conditions.
- Constructed from AISI 304 Stainless steel throughout to meet the highest hygiene standards.
- Developed and produced in ISO 9001 and ISO 14001 certified factory.
- Mounted on legs with height adjustment.
- Rounded internal corners for ease of cleaning.

### Sustainability

- CFC and HCFC free, highly ecological refrigerant type: R290 (ecological gas in foam: cyclopentane). Hydrocarbon refrigerant gas R290 for the lowest environmental impact (GWP=3), to reduce green house and ozone depletion effects.
- 50 mm insulation for energy saving.

### Optional Accessories

- Kit 4 wheels for 250lt refrigerated counter, saladette PNC 880267
- Feet to reach 900mm height for 250lt saladette PNC 881254
- 1/1GN grey rilsan grid PNC 881435

**APPROVAL:** \_\_\_\_\_

Front

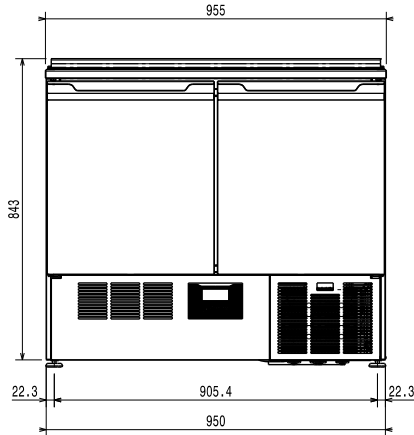

Side

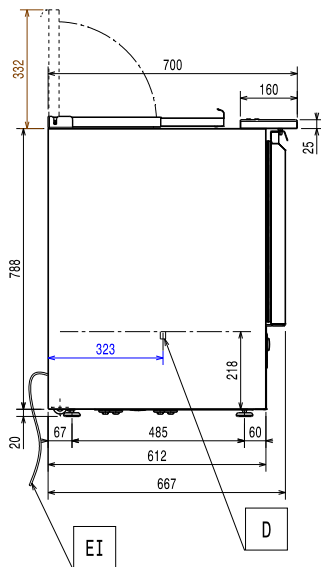

EI = Electrical inlet (power)

Top

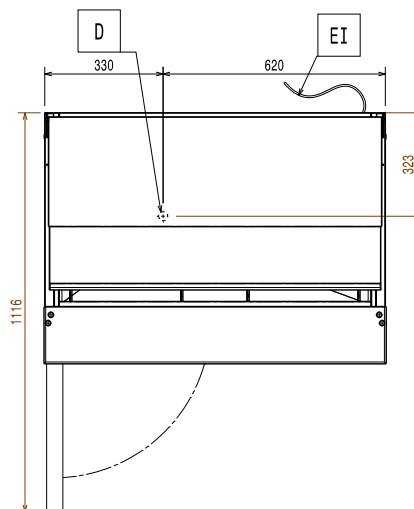
**Electric**
**Supply voltage:**

725107 (SAL25L2C9)

220-240 V/1 ph/50 Hz

**Key Information:**
**Door hinges:** 1 Left+1 Right

**Built-in Compressor and Refrigeration Unit**
**External dimensions, Width:** 950 mm

**External dimensions, Depth:** 700 mm

**External dimensions, Height:** 863 mm

**Depth with doors open:** 1120 mm

**Refrigeration Data**
**Compressor power:** 1/4 hp

**ISO Certificates**
**ISO Standards:** ISO 9001; ISO 14001; ISO 45001; ISO 50001

**Sustainability**
**Refrigerant type:** R290

**Refrigeration power:** 314 W

**Refrigerant weight:** 50 g